

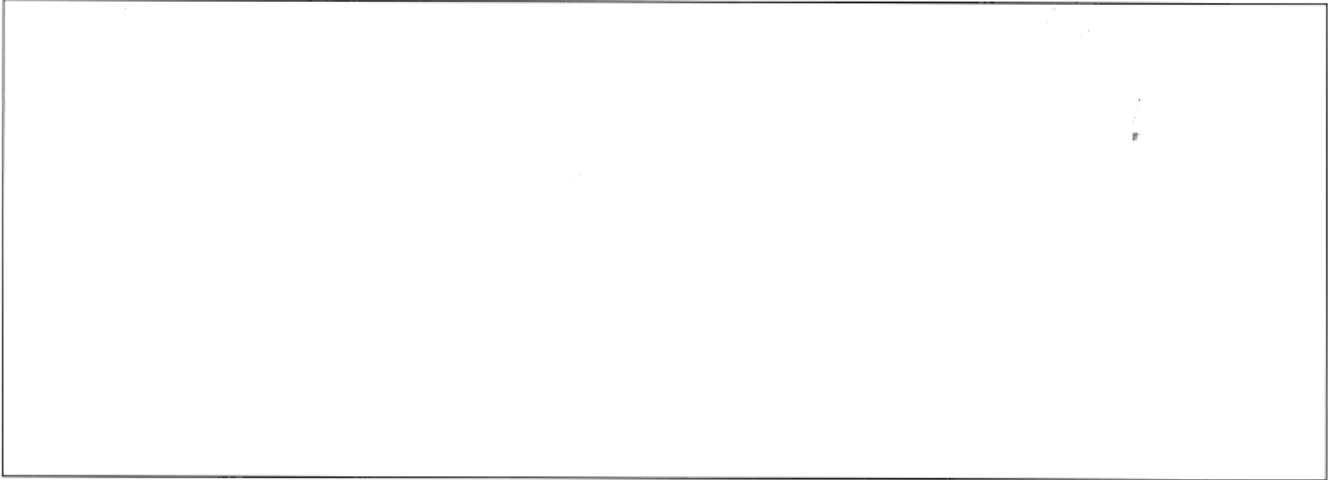

INSTRUCTION MANUAL
EC-DCA
Economy Direct Current
Alarm

192-753-00A

December 1972



GENERAL INFORMATION

1.1 SCOPE OF MANUAL

This manual contains a description, installation and operating instructions, and maintenance instructions for the Economy Model DC Current Alarm. To support any maintenance that might be required, a description of the theory of operation is also included, and a list of replaceable parts is given. A list of recommended spares is also included.

1.2 PURPOSE OF EQUIPMENT

The Economy Model DC Current Alarm (EC-DCA) provides a signal that will operate an alarm system at a predetermined but adjustable value of DC current. As standard equipment, an LED (light-emitting diode) indicator is supplied on the front panel for each trip point to indicate visually the state energized or un-energized.

1.3 GENERAL DESCRIPTION

The unit amplifies the applied input signal, combines an adjustable portion of the amplified signal with a fixed voltage of opposite polarity at one input of a comparator, and then uses the output of the comparator to drive the relay driver amplifier. The signal for the external alarm system is produced by the closing or opening of a relay controlled by the relay driver amplifier. High stability is achieved through the use of feedback in each of the stages other than the relay driver amplifier.

1.4 PHYSICAL DESCRIPTION

The EC-DCA is available in one basic physical configuration. In general, the unit consists of a printed-circuit board enclosed in a rugged molded plastic and metal protective housing. The unit may be installed without further protection, or the entire assembly may be mounted in an enclosure that is oil-tight or water-tight. Only one terminal configuration is used, and specific details for making electrical connections are given in Section 2, Installation Information.

1.5 SPECIFICATIONS

The specifications of the EC-DCA are given in Table 1-1.

TABLE 1-1. EC-DCA SPECIFICATIONS

<u>INPUT RANGES</u>	1-5 mA @ 1000 ohms 4-20 mA @ 250 ohms 10-50 mA @ 100 ohms 1-5 volts @ 1 megohm minimum
<u>FRONT PANEL ADJUSTMENT</u>	
TRIP POINT:	Multiturn front panel adjustment over a range of -5% to +110% of span
<u>OUTPUT</u>	SPDT relay contacts 10A @ 117 VAC non-inductive
<u>REPEATABILITY</u>	Trip point repeats within $\pm 0.1\%$ full span maximum
<u>DEADBAND</u>	1% of span
<u>AMBIENT TEMPERATURE RANGE</u>	-32°F to +158°F (0°C to 70°C)
<u>AMBIENT TEMPERATURE EFFECT</u>	Less than $\pm 0.01\%/^{\circ}\text{F}$ over above range
<u>RESPONSE</u>	80 milliseconds maximum for a step change of 1% of span beyond set points
<u>ISOLATION</u>	Input and output are transformer isolated from power input with no DC connections between them. Both AC and DC powered units have this as standard. All output contacts are relay isolated
<u>POWER INPUT</u>	117 VAC, 240 VAC, 50/60 Hz $\pm 20\%$ standard 5 watts maximum AC, 3 watts @ 24 VDC
LINE VOLTAGE EFFECT:	AC or DC: $\pm 0.01\%/1\%$ line change

1.6 MODEL NUMBERING SYSTEM

Model Numbers describe an instrument's type, functional range, and features. If all accompanying documentation of a unit should be missing, one can still "translate" the Model Number back into a working description of the unit by using the information in this paragraph as a reference.

BASIC EXAMPLE:

EC-DCA/4-20MA/X1/AC

EC-DCA, 4-20 mA input, single trip output in X1 configuration, 117 VAC power.

BASIC INSTRUMENT TYPE:

EC-DCA indicates Economy Model DC Current Alarm

INPUT RANGE:

Numbers: Minimum and maximum input range, generally an industry standard

SC: Selectable Current (i.e., input current range selectable with one of several resistors supplied for this purpose)

OUTPUT RELAY MODES:

X1 X1 indicates that trip-point relay is energized when input signal is below trip point (fail-safe mode); standard unless other option requested

X2 indicates that trip-point relay is deenergized when input signal is below trip point

POWER INPUT:

DC: DC power, 24 VDC $\pm 10\%$ unless stated otherwise, e.g., 45 VDC

AC: AC power, 117 VAC $\pm 10\%$ unless stated otherwise, e.g., 240 VAC

INPUT AND OUTPUT ABBREVIATIONS:

V = volts MA = milliamperes

CALIBRATION PROCEDURES

2.1 GENERAL INSTALLATION INFORMATION

Installation, in general, consists of calibration (when required), mechanical mounting, and making the electrical connections to the unit. The necessary procedures are described in paragraph 2.3 and those following that paragraph. Before actually calibrating the unit, however, the reader should first become familiar with the type of controls on the unit and the tools (if any) required for adjustment; these are described in paragraph 2.2.

2.2 CONTROLS

Several types of controls are provided on standard Moore Industries products. They have been carefully selected to fulfill the necessary electrical requirements and also provide optimum ease of adjustment by the user.

All external controls are multiturn potentiometers that are adjusted with a blade screwdriver NOT MORE THAN 0.1 INCH (2.54 mm) WIDE. USE OF A WIDER BLADE MAY PERMANENTLY DAMAGE THE POTENTIOMETER MOUNTING. This type of potentiometer usually requires 20 turns of the shaft to move the wiper from one end of its range to the other. It is equipped with a slip clutch at either end of its travel to prevent damage if it is turned beyond the wiper stop. Usually a slight change in feel will be noticed when the clutch is slipping; however, if this change is not observed, one can be certain of reaching either end by turning the shaft 20 turns in the desired direction. Controls are connected so turning the shaft clockwise increases the quantity or makes it more positive, and turning the shaft counterclockwise has the opposite effect.

When present, internal adjustable controls are single-turn potentiometers that require a screwdriver with a blade not more than 0.1 inch (2.54 mm) wide. Since these devices do not have slip clutches, care must be used to avoid over-torquing them.

2.3 ADJUSTMENT

Units are checked for proper performance at the factory before they are shipped. However, unless adjustment was requested to a specific trip point, the unit should be adjusted by the user before the unit is placed in service.

A continuously adjustable DC current input signal source with a monitoring device for determining the input amplitude is required for adjustment. The input current monitoring device must have an accuracy within $\pm 0.05\%$ or better. Alternatively, MII Test Set PTS-770 may be used to supply the input signal for adjustment.

To adjust a unit, proceed as follows:

- a. Connect unit and test equipment as shown in Figure 2-1. Initially turn the TRIP-PT.ADJ. potentiometer fully counterclockwise.

- d. Slowly decrease the input signal until the output just untrips. The signal at which the output untrips should be less than the trip-point value by 1% of the span.
- e. Recheck the trip and untrip action of the unit at input signals equal to the trip point and less than this value by 1% of the span. If necessary, readjust the TRIP-PT. ADJ. potentiometer until the desired trip and untrip values are obtained, with an allowable variation of not more than 0.1% of span between successive trip signals and successive untrip signals.
- f. After step (e) has been successfully completed, remove the input signal and then turn off the power input to the unit.

2.4 MECHANICAL INSTALLATION

Figure 2-2 shows the outline dimensions and other installation requirements for this unit.

2.5 ELECTRICAL CONNECTIONS

All electrical connections are made to the terminal block on the unit. The terminals to be used for the electrical connections are indicated on Figure 2-3. The following paragraphs provide additional information on wiring the unit.

2.5.1 General Wiring Techniques

No special wire or cable is required for signal connections to the unit. To avoid transients and stray pickup, it is recommended that twisted conductors be used where they are run close to other services (such as power wiring). On open units supplied with a snap-off cover, dress all wiring up through the opening in the bottom of the cover. Spade-lug connectors are recommended for all wire terminations. All terminals are supplied with 6-32 screws long enough to easily accept three spade-lug connectors.

2.5.2 Power Connections

The unit is designed to be operated from either a DC power source or an AC power source. Refer to paragraph 1.6 for information on how to use the model number to determine the type of power required.

On DC-powered unit, the DC terminal is connected to the + (positive) side of the source, and the DCC terminal is connected to the - (negative) side. The DC source should be regulated to within $\pm 10\%$ of the nominal voltage and should be capable of delivering 3 watts.

EC-DCA/STD

Economy Direct Current Alarm

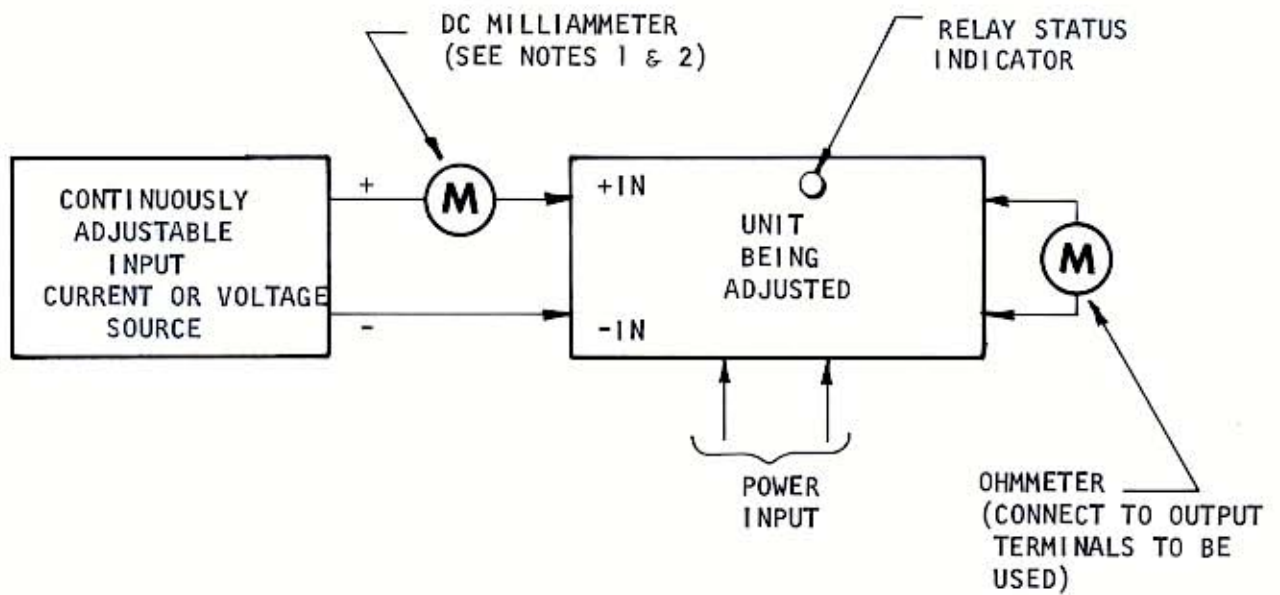

NOTES:

1. INPUT MILLIAMMETER MUST BE ACCURATE TO WITHIN $\pm 0.05\%$.
2. MII TEST SET PTS-770 MAY BE USED FOR INPUT CURRENT SOURCE

Figure 2-1. Test Equipment Setup For Adjustment Of Unit

On AC-powered units, 117 volts AC $\pm 10\%$, 50/60 Hz, 3 VA nominal power is required. The AC terminal should be connected to the ungrounded or "hot" side of the supply, if possible, and the ACC terminal is connected to the common or neutral side.

2.5.3 Selectable Input Resistor

The input resistor is connected to the +IN and -IN terminals. The input range is clearly marked on the front panel adjacent to the input terminals. Use the appropriate resistor value for the needed input range.

EC-DCA/STD

Economy Direct Current Alarm

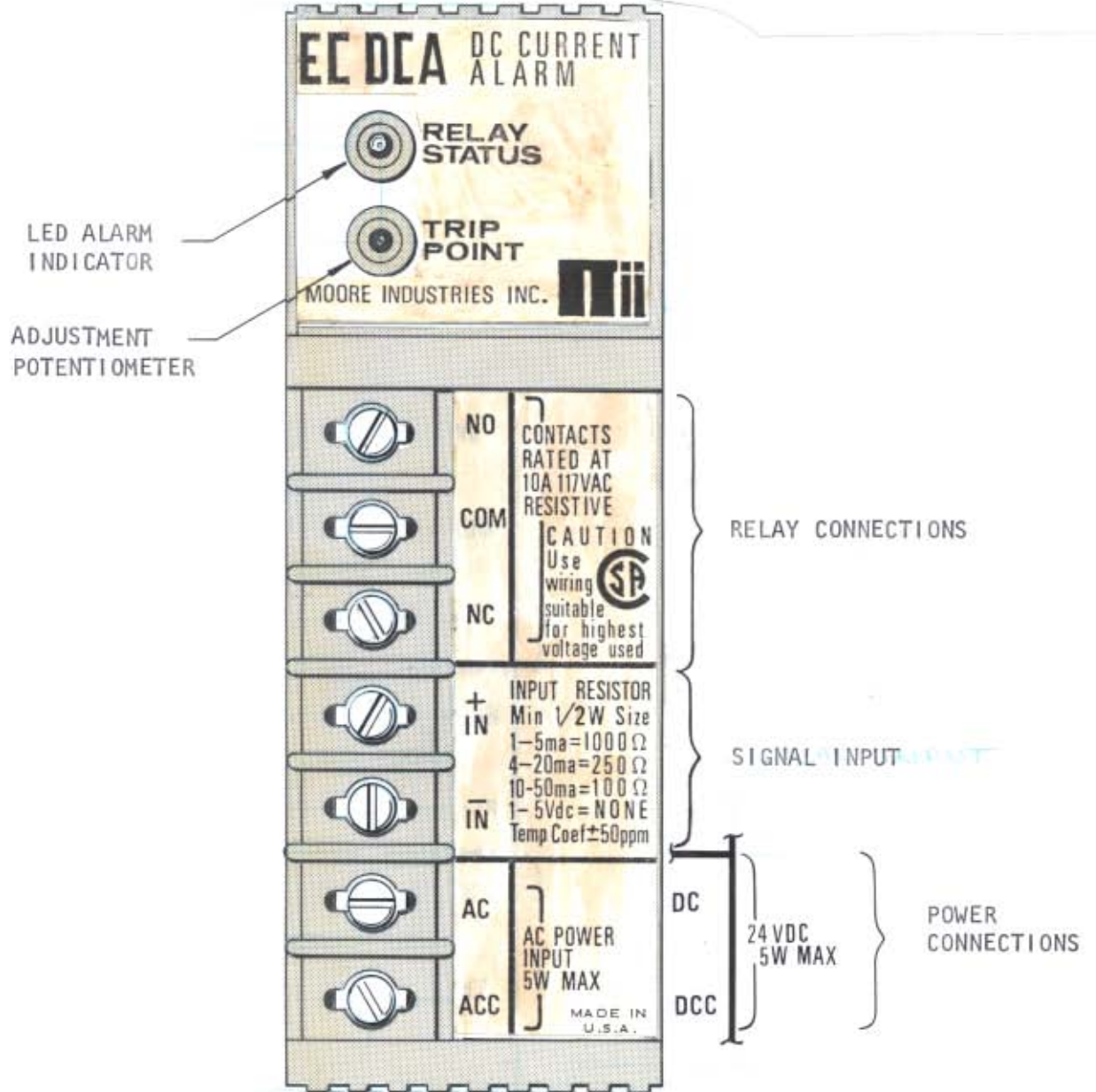
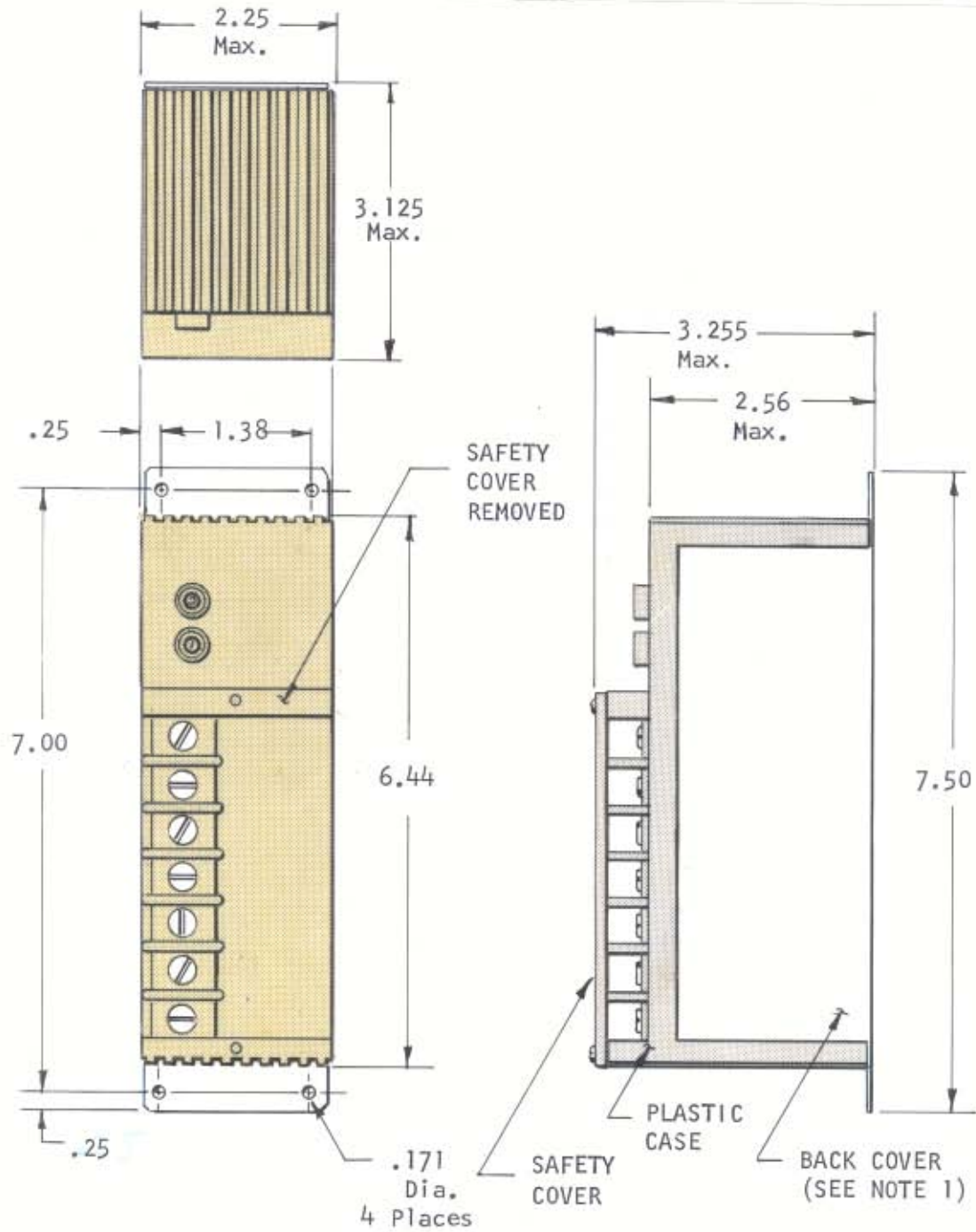

Figure 2-3. Electrical Connections

EC-DCA/STD

Economy Direct Current Alarm



NOTES:

1. BACK COVER IS SECURED TO PLASTIC CASE BY TWO MACHINE SCREWS.

Figure 2-2. Outline & Installation

ECONOMY DIRECT CURRENT ALARMS

INSTALLATION & OPERATION

3.1 OPERATING PROCEDURE

Once adjusted and installed, the unit may be operated unattended. The only control on the outside of the unit is the TRIP-PT.ADJ. potentiometer which, after initial adjustment, needs no further attention. A solid-state indicator associated with the output relay is included on the unit as a standard feature. This indicator informs the operator when an alarm condition has occurred. Note carefully, however, that an illuminated indicator does not necessarily indicate an alarm condition, since a relay may be energized either with a normal (non-alarm) input signal (X1 output configuration, fail-safe operation) or with an alarm input signal (X2 output configuration, non-fail-safe operation). There are no other indicators on the unit. Because the circuit uses highly reliable solid-state components, except for relays, the unit should operate virtually maintenance-free for a long period of time. However, if a malfunction should occur, refer to Section 5 for maintenance information.

A unit may become warm during operation, especially where the ambient temperature is rather high. This is perfectly normal and should not be a cause for concern unless a malfunction is also observed.

THEORY OF OPERATION

4.1 INTRODUCTION

This section describes the theory of operation of the unit. Both the AC- and DC-operated power supplies are covered, and the X1 and X2 output configurations are described. However, a given unit will have either the AC- or the DC-operated power supply and either the X1 or X2 output configuration (see schematic diagram). Therefore, simply disregard those portions of the schematic and the accompanying text that do not apply.

4.2 CIRCUIT DESCRIPTION

The schematic diagram of the unit is near the end of this manual. Refer to this diagram when reading the following paragraphs.

4.2.1 Description Of AC Power-Supply Circuit

In a unit that is operated from AC power, the power supply consists of a power transformer, rectifiers, filters, and regulators to produce positive and negative voltages with respect to common. Referring to the schematic diagram, it is seen that VS1 is connected across the primary of power transformer T1 and suppresses transients that may be present on the power line. AC voltage from the center-tapped secondary of T1 is rectified by CR2 and CR4 to produce positive DC output, and by CR3 and CR5 to produce negative DC output. These outputs are filtered by C2 and C3, and regulated by R20-CR10 and R19-CR9 to produce outputs of +15 and -15 volts as operating voltages for IC1 and IC2. A somewhat higher positive voltage (point C) is utilized for operating the output relay and solid-state indicator. The -15 volt output is also fed through R10 to CR6, which forms a -6.2 volt source that supplies the reference current to one input of IC2.

4.2.2 Description Of Inverter Power-Supply Circuit

In a unit that is operated from DC power, the DC applied to the power inverter is converted to a square wave of approximately 20 KHz by Q1, Q2, and the primaries of T2, functioning as a DC-to-AC inverter. Filter L2-C1 prevents the 20 KHz signal from getting back into the external DC source. CR1 provides protection against damage from inadvertent application of DC of incorrect polarity. The square-wave output from the secondary of T2 is applied to CR2 through CR5, and the action from this point is identical to that described in paragraph 4.2.1.

4.2.3 Description Of Input Buffer Circuit

The input buffer consists of IC1 and associated components. The stage serves to isolate the input-signal source from later stages in the unit so adjustments in the value of the trip point will not affect the input signal. R5 provides the proper termination for the input-signal source connected to the +IN and -IN terminals. The signal at the +IN terminal is applied through R6 to the non-inverting input (pin 3) of IC1, which is used as a buffer amplifier with unity

gain and a low output impedance to reliably drive the following stage. R6 and C4 form a low-pass (5 Hz at 3-dB point) filter to remove any noise or other high-frequency components from the signal applied to IC1. R8 provides feedback to the inverting input of IC1.

4.2.4 Description Of Comparator Circuit

The comparator consists of IC2 and associated components. The output from IC1 is applied through R9 and the TRIP-PT. ADJ. potentiometer to the inverting input (pin 2) of IC2. The -6.2 volts from CR6 supplies current through R11 to pin 2 of IC2 to cancel in part the signal supplied by IC1. With a given signal applied to the input of the unit, the net current applied to pin 2 is determined by the setting of the TRIP-PT. ADJ. potentiometer. As long as the input applied to the unit causes IC1 to supply less current to pin 2 of IC2 than is supplied through R11 by CR6, the output of IC2 will be at some stable positive value determined by the setting of the TRIP-PT. ADJ. potentiometer. Under this condition, a fraction of the positive output from IC2, determined by R16 and R17, is applied to the non-inverting input (pin 3) of IC2, thus stabilizing the output of this stage. If the applied input causes the output of IC1 to rise and apply more current to pin 2 of IC2 than is supplied through R11, the signal from IC1 then completely determines the output from IC2 and the latter abruptly shifts to a negative value. Again feedback through R17 to pin 3 of IC2 locks the output of this stage at the new (negative) value, and pin 3 assumes a new potential that is now negative with respect to common.

When the applied input again becomes normal (i.e., the output current from IC1 falls below that supplied by CR6, the output of IC2 will almost immediately return to its original positive state. However, because feedback through R17 keeps pin 3 negative, the output from IC2 remains negative until the driving signal from IC1 decreases to a value below that of the signal at pin 3 of IC2. When this occurs, the output of IC2 abruptly returns to its original positive state. Because the level of signal at pin 3 shifts when the output of IC2 changes from positive to negative, the value of input signal at which IC2 returns to positive is somewhat lower than that at which the change occurred from positive to negative output. The difference between these two values is called the deadband, and it is, about 1% of the input span (i.e., 1% of 4 volts or 40 millivolts).

4.2.5 Description Of Relay Driver Circuit In X1 Output Configuration

The relay driver consists of either a single stage, Q3, or Q3 and Q4, depending on whether the X1 or X2 configuration has been selected. The output of IC2 is applied through R18 to Q3. Under non-alarm conditions, the output of IC2 is positive and, in the X1 output configuration, this signal turns on Q3, thereby energizing K1 through J1. J2 is not used, thus making Q4 inactive since it can not receive any collector voltage. The RELAY STATUS indicator, a light-emitting diode (LED) also comes on, thereby indicating that K1 is energized (alarm not tripped, for X1 output configuration). The voltage at point C is used to power K1 and the RELAY STATUS indicator. When an input corresponding to an alarm condition occurs, the output from IC2 becomes negative. This negative output

turns off Q1, thereby deenergizing K1 and turning off the RELAY STATUS indicator. With K1 deenergized, the alarm circuit is actuated. This configuration of K1 is fail-safe, since the alarm will be actuated if the power input to the unit fails. If the RELAY STATUS indicator should fail open, CR8 will allow K1 to still become energized, thus preventing a complete breakdown of the system.

4.2.6 Description Of Relay Driver Circuit In X2 Output Configuration

In the X2 output configuration, K1 must remain unenergized when an alarm condition does not exist and must energize to trip the alarm. For this configuration, J1 is omitted and J2 is used, thus allowing Q3 to drive Q4 through R14. Since a polarity inversion occurs in each output stage (Q3 and Q4), a positive output from IC2 will cause Q3 to produce an output that will keep Q4 off, thereby keeping K1 unenergized and the light-emitting diode (LED) RELAY STATUS indicator off. Conversely, when the output of IC2 becomes negative (as a result of an alarm condition), Q3 is turned off and the high output at its collector turns Q4 on. K1 is then energized and the RELAY STATUS indicator is turned on. Operating K1 in this manner is not fail-safe, since K1 will not change state (i.e., will remain deenergized) if power input to the unit fails. If the RELAY STATUS indicator should fail open, CR8 will allow K1 to still become energized, thus preventing a complete breakdown of the system.

MAINTENANCE & TROUBLESHOOTING

5.1 INTRODUCTION

This section contains information on maintenance of the unit. General troubleshooting procedures are given, using conventional signal-tracing techniques. Precautions and special techniques used to replace components are also described.

5.2 PERIODIC MAINTENANCE

It is suggested that the adjustment of the unit be checked approximately every 6 months as described in Section 2. No other periodic maintenance is required.

5.3 CORRECTIVE MAINTENANCE

The following paragraphs provide information on corrective maintenance of the unit. Corrective maintenance should be carried out only by qualified personnel who have read and thoroughly understand the description of circuit operation given in Section 4.

5.3.1 Disassembly

To troubleshoot the unit, it is first necessary to disassemble it so the circuit board is exposed. Be sure to disconnect the input signal and turn off the power input before disassembling the unit. First remove the unit from its installed position, and then disassemble the unit as follows to gain access to the circuit board:

- a. Remove the two Phillips-head screws at the back of the unit.
- b. Slide the metal cover free of the plastic case. Points on the circuit board may now be reached for troubleshooting.

5.3.2 Troubleshooting

The schematic diagram includes flagged numbers or letters at various points in the circuit. Table 5-1 gives the voltages and waveforms at these points for specified input-signal conditions. The assembly drawing shows the physical locations of the parts on the circuit board. Bear in mind that the circuit board is protected with a moisture-resistant coating. Therefore, it may be necessary to use a needle-point probe and exert a fair amount of pressure to break through the coating when it is desired to observe the signal or voltage at a specific point. When connecting a probe to a component on the circuit board, exercise care to make sure the probe does not short-circuit to an adjacent component. In general, troubleshooting is carried out by tracing the signal with an oscilloscope and referring to the schematic diagram to determine what component might be causing an observed abnormal indication. If the

original symptom was a complete failure of the unit to operate, the most logical components to suspect are those associated with the power supply in the unit (including the voltage regulators). If the unit tripped (or failed to trip) with an applied input that should have produced the opposite condition, check the outputs from the power supply and, if these are normal apply a standard input signal and trace the resulting signal through the unit.

5.3.3 Component Replacement Techniques And General Precautions

Replace all defective components with identical parts. Refer to the assembly drawing for a list of replacement parts. The letter S and a number, all enclosed in a circle, appear after the description of certain parts in this list. The number indicates the number of spares recommended to be kept on hand for that part, per unit, for up to ten units of the same type. For more than ten units, a spares complement of 10% on the indicated parts should be used.

Most parts used in the unit are quite small and are located in a confined area. Therefore, small hand tools are a necessity when servicing the unit. The following is a summary of the general techniques and precautions that should be observed to prevent damage to components in the unit:

- a. Use a transformer-operated low-voltage soldering iron with a grounded tip and rated at not more than 50 watts. A temperature-controlled tip is desirable.
- b. Use extreme care when unsoldering the leads to any component. Do not keep the soldering iron on a point for more than a few seconds at a time. Use a suction-type solder-removing tool (solder sucker) as an aid in unsoldering transistors and integrated circuits. The protective coating on the unit may be removed with trichlorethane or equivalent. Be sure adequate ventilation is provided when using this or any other chemical.





NOTE

Unused connections on integrated circuits are left unsoldered to aid in removal. Refer to the assembly drawing for more complete information.

- c. Do not excessively bend or twist the leads of small components; they break easily.
- d. Before removing a component, observe the lead dress. Be sure that the lead dress of the replacement is the same as that of the original.

- e. Remove all flux from soldered joints with trichlorethane or equivalent.
- f. Test and, if necessary, readjust the unit for proper operation by the procedure given in Section 2. When the performance of the unit is known to be satisfactory, apply clear acrylic to reseal the unit where required.
- g. Check that all leads are clear of the board edge before reinstalling the board into its case.
- h. When reassembling the unit, be sure to use the same screws (or screws of the same size) as the ones removed. Longer screws will damage the unit.

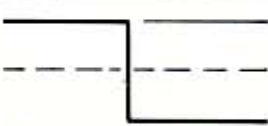
TABLE 5-1. WAVEFORMS & VOLTAGES

TEST POINT	WAVE FORM AND AMPLITUDE OR VOLTAGE LEVEL
1	 <p>1 TO 5 DEPENDING ON INPUT CURRENT</p> <p>0</p>
2	 <p>1 TO 5 DEPENDING ON THE SETTING OF POTS</p> <p>0</p>
3	 <p>+10V RELAY ENERGIZED</p> <p>0</p> <p>10V RELAY DEENERGIZED</p>
4	 <p>+15V TO +18V RELAY DEENERGIZED</p> <p>0 RELAY ENERGIZED</p>

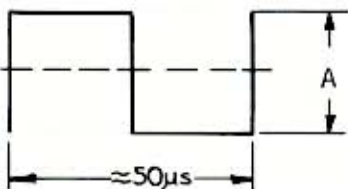
DC OPERATED UNITS				
TEST POINT	WAVE FORM	POWER INPUT AND WAVE FORM AMPLITUDE		
		24 VDC	45 VDC	65 VDC
5 WITH RESPECT TO DCC		48V	90V	130V

UNIT DOCUMENTATION

6.1 GENERAL

This section consists of a computer print-out table that provides parts identification information for the unit. Wiring lists have been provided in this section as an aid to the maintenance personnel.

Parts information is grouped according to the number of assemblies. If the unit contains two PC boards, the table will be divided into two major sections: one section will contain information related to PC1 and the other section will list PC2 components information. Each major section in the table contains a complete parts list headed LIST OF MATERIALS specifying which PC board it is describing. This list is usually found at the end of the section. The list of materials consists of the following headings:

ITEM: A reference numeral used for data processing and not used by maintenance personnel.

NAME: Gives the nomenclature of the part.

DESCRIPTION: Identifies the component by manufacturer's part number, usually followed by component's parameters or value.

REF: Lists the reference designation for the components described in Section 4 and illustrated in the schematics and assembly drawings.

PART NUMBER: This column specifies the Moore Industries assigned part number. This is the part identification required when ordering parts from Moore Industries.

SPARE: The numeral in this column specifies the recommended number of component spares per unit type that should be kept on hand by maintenance personnel.

6.2 GLOSSARY OF ABBREVIATIONS

C	Capacitor
CR	Diode — Zener included
HW	Special hardware
J	Connecting buss wire
L	Inductor
LB	Label
PC	Printed circuit board
R	Resistor

T	Transformer
IC	Integrated circuit
Q	Transistor
LED	Light emitting diode
TB	Terminal block
VS	Voltage regulating varistor
VR	Voltage Regulator



MOORE INDUSTRIES
16650 Schoenborn Street
Sepulveda, California 91343

DO NOT SCALE DRAWING		
TOLERANCES UNLESS NOTED	DRAWN T. HART	4-16-76
X ±.1	CHECKED	3/29/76
XX ±.03	DESIGNED	
XXX ±.010	INVENTOR	
ANGLES ±30°	SCALE	

SCHEMATIC STANDARD
EC-DCA

REVISION NUMBER 192-403-00	REVISION F
DATE 7-24-76	BY FL
APPROVED BY ECO	APPROVED BY FL

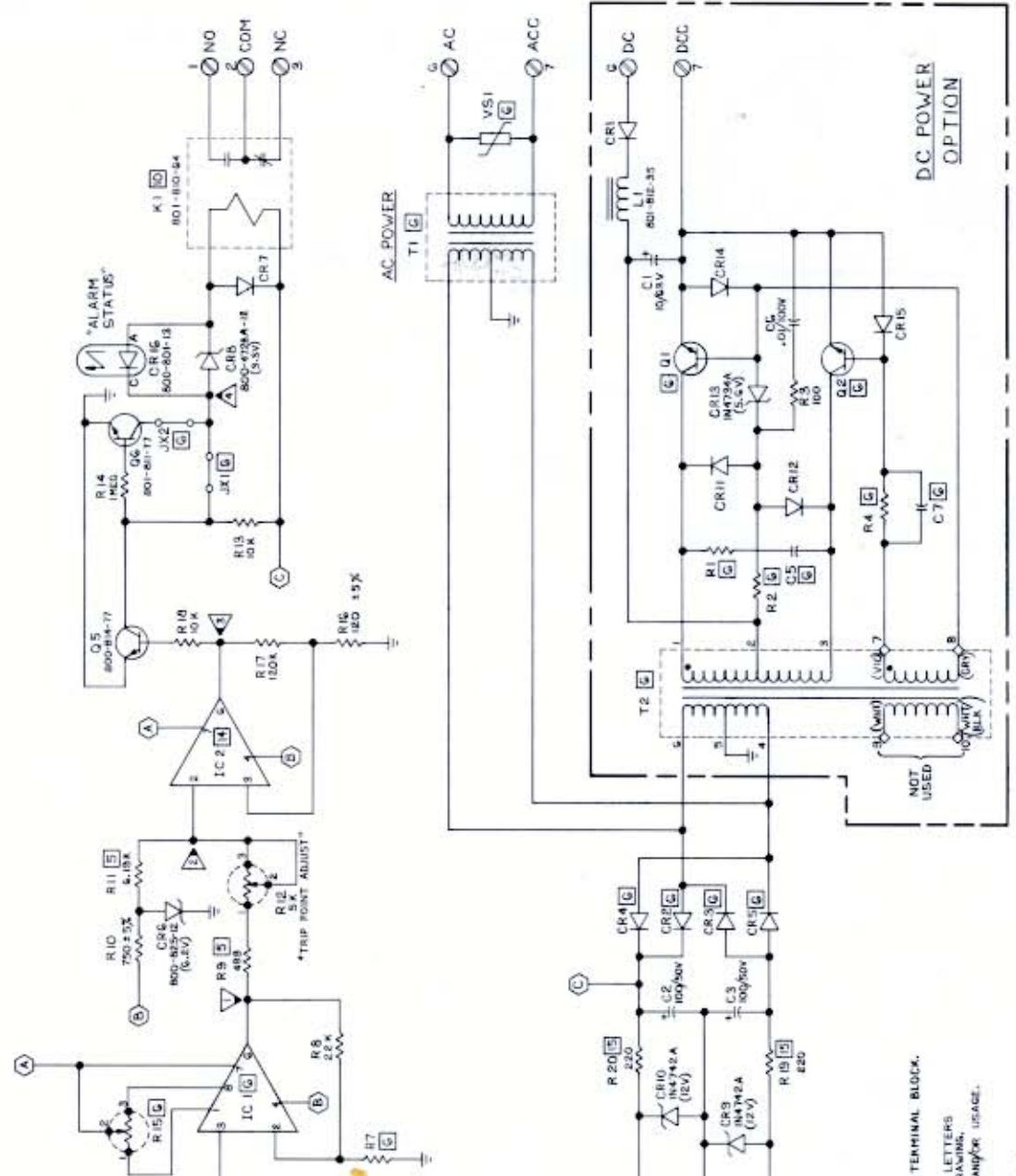

- 1. CARBON COMP. RESISTOR, $\frac{1}{4}$ W, $\pm 10\%$.
 - 2. IC2 IS FULL P/W 800-852-31.
 - 3. INDICATES TEST POINT; FILLED END IS POINTER.
 - 4. SEE SECTION 5 OF MANUAL, "MAINTENANCE".
 - 5. ITEM NOT MOUNTED ON P.C. BOARD.
 - 6. \perp INDICATES COMMON (GROUND).
 - 7. CONTACTS W/ATE AT 10 AMPS @ 117 VAC, RESISTIVE.
 - 8. INDICATES TERMINAL BLOCK POSITION, 7 POSITION TERMINAL BLOCK.
 - 9. INDICATES IDENTIFIED WIRING PAD ON P.C.B.
 - 10. INDICATES ELECTRICAL COMMON (SAME LETTERS). LETTERS DO NOT APPEAR ON P.C. BOARD ON ASSEMBLY DRAWING.
 - 11. SEE LIST OF MATERIALS FOR VALUE, PART NUMBER, and/or USAGE.
 - 12. METAL FILM RESISTOR; RNS5C, $\pm 1\%$.
 - 13. METAL FILM RESISTOR; RNS5C, $\pm 1\%$.
 - 14. ALL POTENTIOMETERS INCREASE CLOCKWISE FROM 1 TO 8.
 - 15. DIODES ARE IN4148; RESISTORS ARE $\frac{1}{4}$ W, CARBON COMP, $\pm 10\%$.
 - 16. RESISTANCE IN OHMS; CAPACITANCE IN MICROFARADS.
- NOTES: UNLESS OTHERWISE SPECIFIED.

PAGE 1 OF 2

192-503-00 F
 STD. EC-DCA, PCI ASSY PG. 1

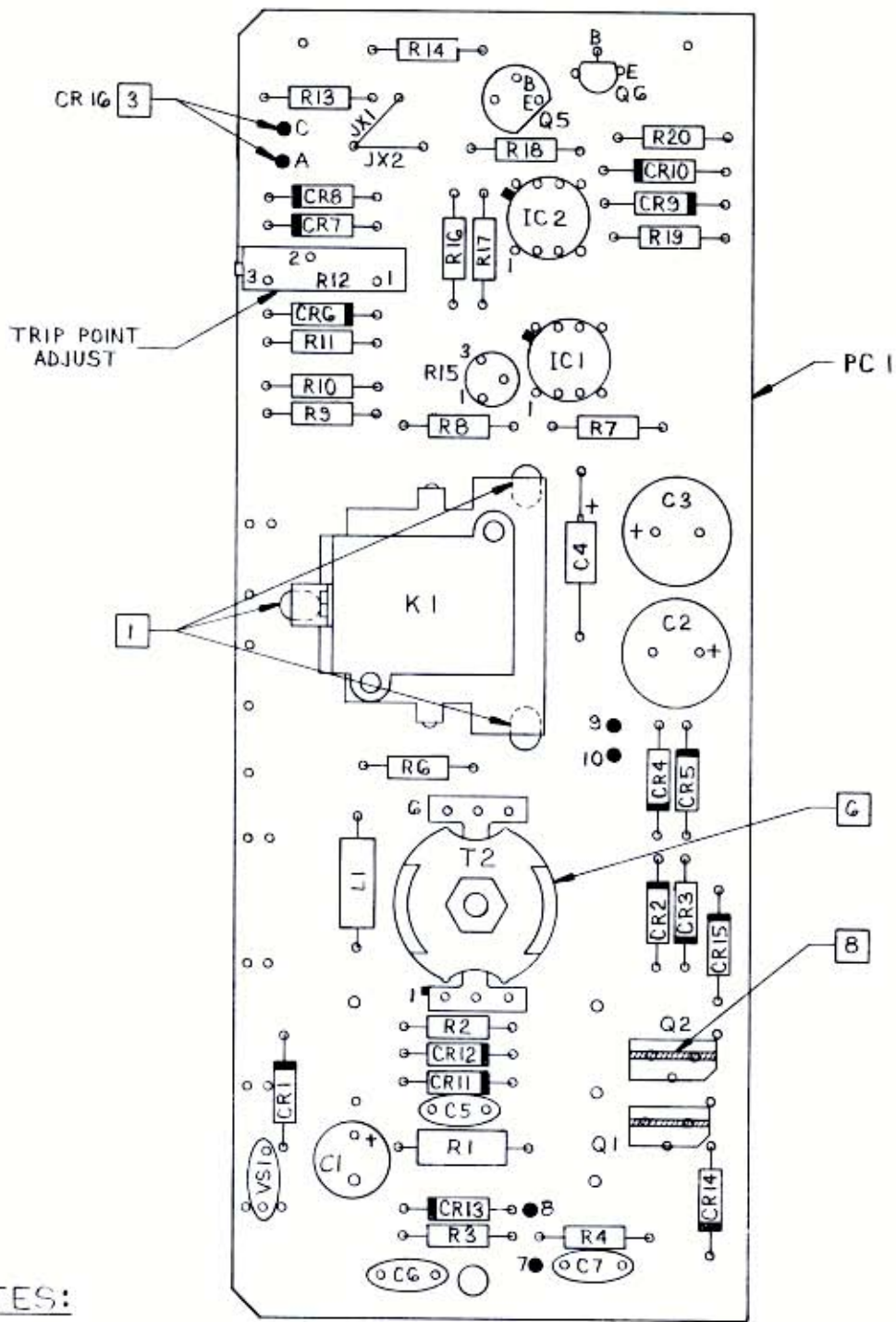

NOTES:

1. BEND K1 TERMINALS INWARD.
2. BEND T1 TABS INWARD.
3. DO NOT INSTALL "ALARM STATUS" UNTIL PCI ASSEMBLY HAS BEEN SOLDERED IN PLACE AT NEXT ASSEMBLY, SEE PAGE 2 FOR MOUNTING DETAIL.
4. ALL JUMPERS ARE 22 AWG BUSS, TEFLON SLEEVED AS REQUIRED.
5. ALL LEADS MUST BE SOLDERED TO PADS EXCEPT UNUSED I.C. LEADS.
6. SEE PAGE 2 FOR MOUNTING DETAILS OF T1, T2, & R5.
7. SOLDER R5 TO HW6 & HW7.
8. SLEEVE METAL TAB OF Q2 WITH CLEAR SHRINK TUBING.

PAGE 2 OF 2

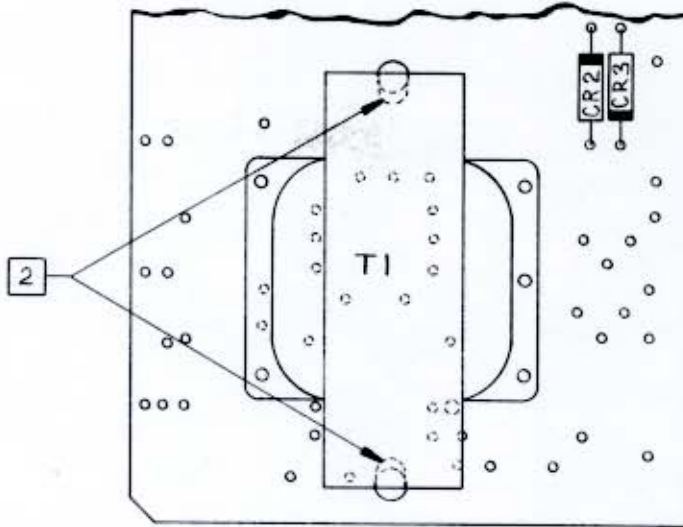

MOUNTING DETAIL FOR T1

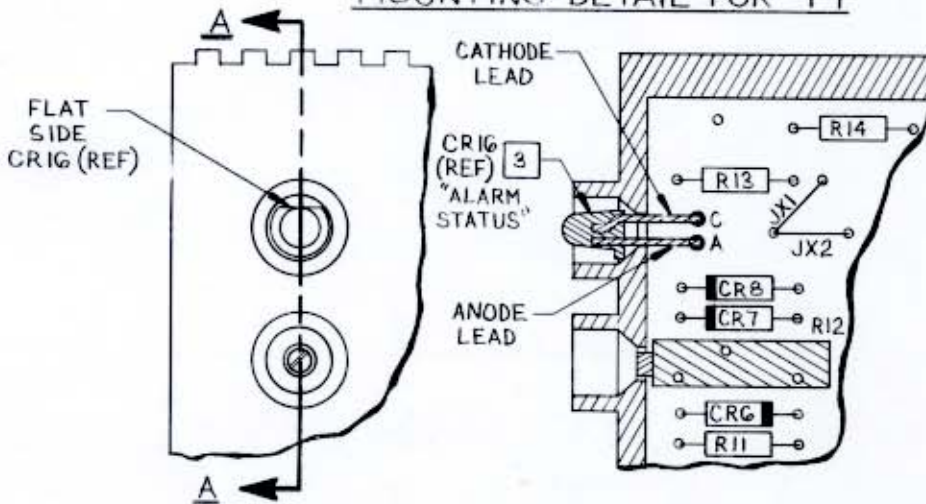

FRONT OF CASE

VIEW AA

MOUNTING DETAIL FOR CRIG

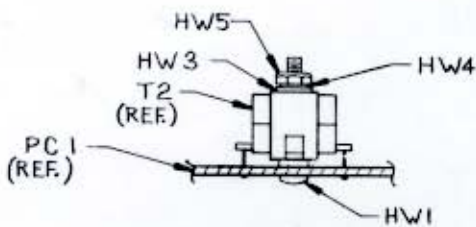

MOUNTING DETAIL FOR T2 (FULL SCALE)

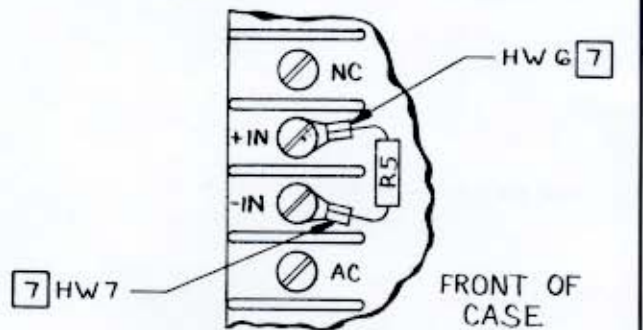

MOUNTING DETAIL FOR R5 (FULL SCALE)

192-503-00 F
 STD EC-DCA, PCI ASS'Y

PG. 2

23

RETURN PROCEDURES

To return equipment to Moore Industries for repair, follow these four steps:

1. Call Moore Industries and request a Returned Material Authorization (RMA) number.

Warranty Repair –

If you are unsure if your unit is still under warranty, we can use the unit's serial number to verify the warranty status for you over the phone. Be sure to include the RMA number on all documentation.

Non-Warranty Repair –

If your unit is out of warranty, be prepared to give us a Purchase Order number when you call. In most cases, we will be able to quote you the repair costs at that time. The repair price you are quoted will be a "Not To Exceed" price, which means that the actual repair costs may be less than the quote. Be sure to include the RMA number on all documentation.

2. Provide us with the following documentation:
 - a) A note listing the symptoms that indicate the unit needs repair
 - b) Complete shipping information for return of the equipment after repair
 - c) The name and phone number of the person to contact if questions arise at the factory
3. Use sufficient packing material and carefully pack the equipment in a sturdy shipping container.
4. Ship the equipment to the Moore Industries location nearest you.

The returned equipment will be inspected and tested at the factory. A Moore Industries representative will contact the person designated on your documentation if more information is needed. The repaired equipment, or its replacement, will be returned to you in accordance with the shipping instructions furnished in your documentation.

WARRANTY DISCLAIMER

THE COMPANY MAKES NO EXPRESS, IMPLIED OR STATUTORY WARRANTIES (INCLUDING ANY WARRANTY OF MERCHANTABILITY OR OF FITNESS FOR A PARTICULAR PURPOSE) WITH RESPECT TO ANY GOODS OR SERVICES SOLD BY THE COMPANY. THE COMPANY DISCLAIMS ALL WARRANTIES ARISING FROM ANY COURSE OF DEALING OR TRADE USAGE, AND ANY BUYER OF GOODS OR SERVICES FROM THE COMPANY ACKNOWLEDGES THAT THERE ARE NO WARRANTIES IMPLIED BY CUSTOM OR USAGE IN THE TRADE OF THE BUYER AND OF THE COMPANY, AND THAT ANY PRIOR DEALINGS OF THE BUYER WITH THE COMPANY DO NOT IMPLY THAT THE COMPANY WARRANTS THE GOODS OR SERVICES IN ANY WAY.

ANY BUYER OF GOODS OR SERVICES FROM THE COMPANY AGREES WITH THE COMPANY THAT THE SOLE AND EXCLUSIVE REMEDIES FOR BREACH OF ANY WARRANTY CONCERNING THE GOODS OR SERVICES SHALL BE FOR THE COMPANY, AT ITS OPTION, TO REPAIR OR REPLACE THE GOODS OR SERVICES OR REFUND THE PURCHASE PRICE. THE COMPANY SHALL IN NO EVENT BE LIABLE FOR ANY CONSEQUENTIAL OR INCIDENTAL DAMAGES EVEN IF THE COMPANY FAILS IN ANY ATTEMPT TO REMEDY DEFECTS IN THE GOODS OR SERVICES, BUT IN SUCH CASE THE BUYER SHALL BE ENTITLED TO NO MORE THAN A REFUND OF ALL MONIES PAID TO THE COMPANY BY THE BUYER FOR PURCHASE OF THE GOODS OR SERVICES.

ANY CAUSE OF ACTION FOR BREACH OF ANY WARRANTY BY THE COMPANY SHALL BE BARRED UNLESS THE COMPANY RECEIVES FROM THE BUYER A WRITTEN NOTICE OF THE ALLEGED DEFECT OR BREACH WITHIN TEN DAYS FROM THE EARLIEST DATE ON WHICH THE BUYER COULD REASONABLY HAVE DISCOVERED THE ALLEGED DEFECT OR BREACH, AND NO ACTION FOR THE BREACH OF ANY WARRANTY SHALL BE COMMENCED BY THE BUYER ANY LATER THAN TWELVE MONTHS FROM THE EARLIEST DATE ON WHICH THE BUYER COULD REASONABLY HAVE DISCOVERED THE ALLEGED DEFECT OR BREACH.

RETURN POLICY

For a period of thirty-six (36) months from the date of shipment, and under normal conditions of use and service, Moore Industries ("The Company") will at its option replace, repair or refund the purchase price for any of its manufactured products found, upon return to the Company (transportation charges prepaid and otherwise in accordance with the return procedures established by The Company), to be defective in material or workmanship. This policy extends to the original Buyer only and not to Buyer's customers or the users of Buyer's products, unless Buyer is an engineering contractor in which case the policy shall extend to Buyer's immediate customer only. This policy shall not apply if the product has been subject to alteration, misuse, accident, neglect or improper application, installation, or operation. THE COMPANY SHALL IN NO EVENT BE LIABLE FOR ANY INCIDENTAL OR CONSEQUENTIAL DAMAGES.



WORLDWIDE • www.miinet.com

United States • info@miinet.com Tel: (818) 894-7111 • FAX: (818) 891-2816	Belgium • info@mooreind.be Tel: 03/448.10.18 • FAX: 03/440.17.97	China • sales@mooreind.sh.cn Tel: 86-21-62491499 • FAX: 86-21-62490635
Australia • sales@mooreind.com.au Tel: (02) 8536-7200 • FAX: (02) 9525-7296	The Netherlands • sales@mooreind.nl Tel: (0)344-617971 • FAX: (0)344-615920	United Kingdom • sales@mooreind.com Tel: 01293 514488 • FAX: 01293 536852